



POST HOLE DIGGER OPERATION AND ASSEMBLY MANUAL



Ag Pro Australia Pty Ltd

3730 Harmony Way

Harcourt

Victoria 3453

1300 121 131

agpro@agproproducts.com.au

CONTENTS

CONTENTS	2
SAFETY INSTRUCTIONS	3
OPERATION	8
SERVICE AND MAINTENANCE	12
PARTS LIST	15

SAFETY INSTRUCTIONS



Before operating the Post hole digger read the following safety instructions. Failure to comply with these warnings may result in serious injury or death.

CONGRATULATIONS! On the purchase of your new Post hole digger. This information is to assist you in preparing, operating and maintaining your Post hole digger. Please read and understand the information completely before operating your Posthole digger, paying special attention to all the safety details. Keep this manual handy for a ready reference.

1.1 Safety First

YOU are responsible for the SAFE operation and maintenance of your Post hole digger. YOU must ensure that you and anyone else who is going to operate, maintain or work around the Post hole digger is familiar with the operating and maintenance procedures and related SAFETY information contained in this manual. This manual will take you step-by-step through your working day and alert you to all good safety practices that should be adhered to while operating the Post hole digger.

Remember, YOU are the key to safety. Good safety practices not only protect you but also the people around you. Make these practices a working part of your safety program. Be certain that EVERYONE operating this equipment is familiar with the recommended operating and maintenance procedures and follows all the safety precautions. Most accidents can be prevented. Do not risk injury of death by ignoring good safety practices.

- 1 Post hole digger owners must give operating instructions to operators or employees before allowing them to operate the machine.
- 2 The most important safety feature on this equipment is a SAFE operator. It is the operator's responsibility to read and understand ALL Safety and Operating instructions in the manual and to follow these. All accidents can be avoided.
- 3 A person who has not read and understood all operating and safety instructions is not qualified to operate the machine. An untrained operator jeopardise himself and bystanders to possible serious injury or death.
- 4 Do not modify the equipment in any way. Unauthorized modification may weaken the function and/or safety and could affect the life of the equipment.
- 5 Think SAFETY! Work SAFELY!

1.2 General Safety

1. These post hole diggers are designed and manufactured only for the purpose of boring holes in earth and clay materials. Under no circumstances should they be used for any other purpose
2. Before using the post hole digger, carefully read and ensure you understand the contents of this Safety Operator's Manual and the contents of the Operators Manual for the associated tractor, including all the relevant safety instructions.
3. Never allow an improperly trained person, child or anyone who is not familiar with the safety rules and operating instructions to attach or operate the post hole digger.
4. Do not leave the tractor seat or allow any person within ten meters of the post hole digger while it is in operation. Serious personal injury or death may result if any attempt is made to assist the digger operation by hand.

SAFETY INSTRUCTIONS

5. Do not operate the digger on steep hillsides.
6. Do not operate the digger with any person within ten meters of the machine.
7. Wear ear protection when operating the post hole digger.
8. Refer to the tractor operators manual for safe working loads, including any counter-weighting that may be required to balance the weight of the post hole digger.
9. Before operating the post hole digger, check all the pins, bolts and connection to ensure they are all securely in place. Replace any damaged or worn parts immediately.
10. Never perform service or maintenance while the PTO is engaged, or the tractor engine is on.
11. Check the gearbox oil level and safety clutch adjustment before using the post hole digger.
12. Ensure that there are no underground electrical cables, telephone cables, gas, water, sewerage or drainage pipes in the area to be drilled. If in doubt about any of the above do not start digging until the situation have been fully investigated and it is safe to begin.
13. Exercise extreme care when operating in wet or slippery conditions, or on sloping or uneven terrain. Allow for the effect that the weight of the post hole digger has on the tractor's stability. Refer to the tractors operating and safety instructions.
14. When using the post hole digger it is most important that all the safety guards are fully maintained, in place and operating correctly.
15. Always operate the post hole digger from the tractor seat.
16. Never clear earth away from the auger whilst it is operating.
17. Never allow a person to pull down on the digger boom or attach any type of counterweight to the boom to increase penetration.
18. Before dismounting from the tractor or allowing any person to approach the post hole digger, disengage the PTO, switch off the tractor engine and apply the parking brake.
19. Ensure the tractor engine is switched off and the parking brake is applied before performing any inspection or maintenance on the digger. If it is necessary to raise the machine for such work ensure it is properly supported. Do not rely on the tractor hydraulics for support.
20. Never allow any person to ride on the post hole digger or the tractor when the digger is attached.
21. Never use alcoholic beverages or drugs which can hinder alertness or coordination while operating this equipment. Consult your doctor about operating this machine while taking prescription medications. Review the safety instructions with all users annually.
22. Ensure maintenance is carried out regularly by a qualified person. This is particularly important on moving parts such as the P.T.O. If wearing parts are not properly maintained, driven parts can fly off at high speed causing damage to the machine, operator and bystanders.

1.3 Storage Safety

1. Store the machine in an area away from human activity.
2. Do not permit children to play on or around the stored machine.
3. Store the machine in a dry, level area.
4. Clean grease and oil as required and protect it from the elements.

SAFETY INSTRUCTIONS

1.4 Maintenance Safety

1. Good maintenance is your responsibility. Poor maintenance is an invitation to trouble.
2. Follow good shop practices.
3. Keep service area clean and dry.
4. Be sure electrical outlets and tools are properly grounded.
5. Use adequate light for the job at hand.
6. Make sure there is plenty of ventilation. Never operate the engine in a closed building. The exhaust fumes may cause asphyxiation.
7. Before working on this machine, shut off the engine, set the brakes, and remove the ignition key.
8. Never work under equipment unless it is secured by a mechanical stand.
9. Use personal protection devices such as eye, hand and hearing protectors, when performing any service or maintenance work. Use heavy gloves when handling blades.
10. Only use genuine parts for service and maintenance.
11. A fire extinguisher and first aid kit should be kept readily accessible while performing maintenance on this equipment.
12. Periodically tighten all bolts, nuts and screws and check that all pins are properly installed to ensure unit is in a safe condition.
13. When completing a maintenance or service function, make sure all safety shields and devices are installed before placing machine in service.

SAFETY INSTRUCTIONS

1.5 Safety & Model Decal

The position of safety decals are shown in the illustrations below. Good safety requires that you familiarize yourself with the various safety signs, and increase your **SAFETY AWARENESS**.

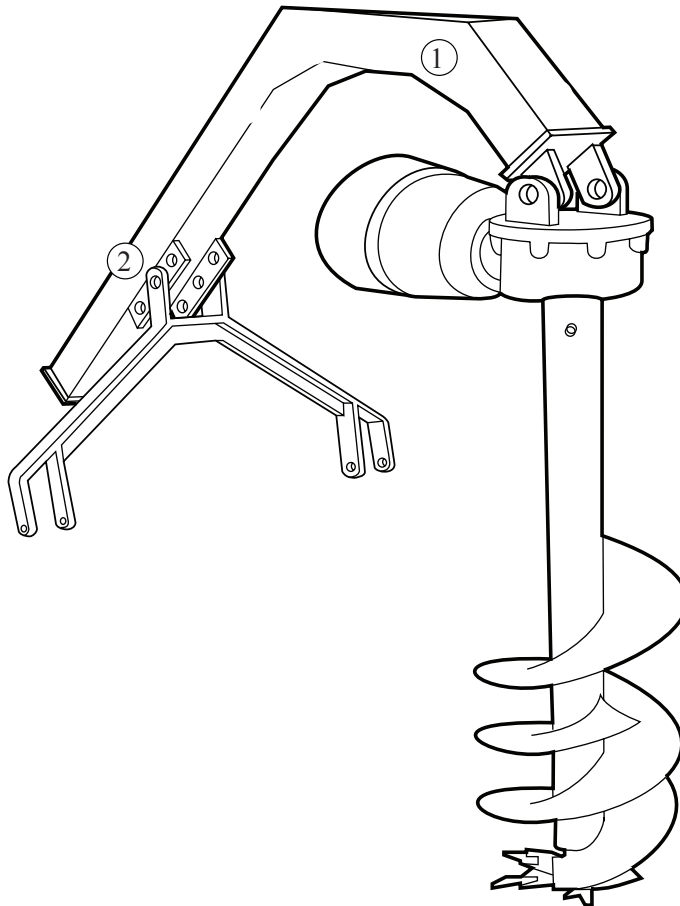

①



②



SAFETY INSTRUCTIONS

The Post Hole Digger is delivered in five separate components.

- 1 Main support boom (jib)
- 2 'A' Frame (with two 'cat 1' lower link pins and 'jib' pivot pin)
- 3 Gear Box Slip Clutch and Safety Cover (and mounting pin)
- 4 PTO Drive Shaft
- 5 Auger (and two shear bolts)

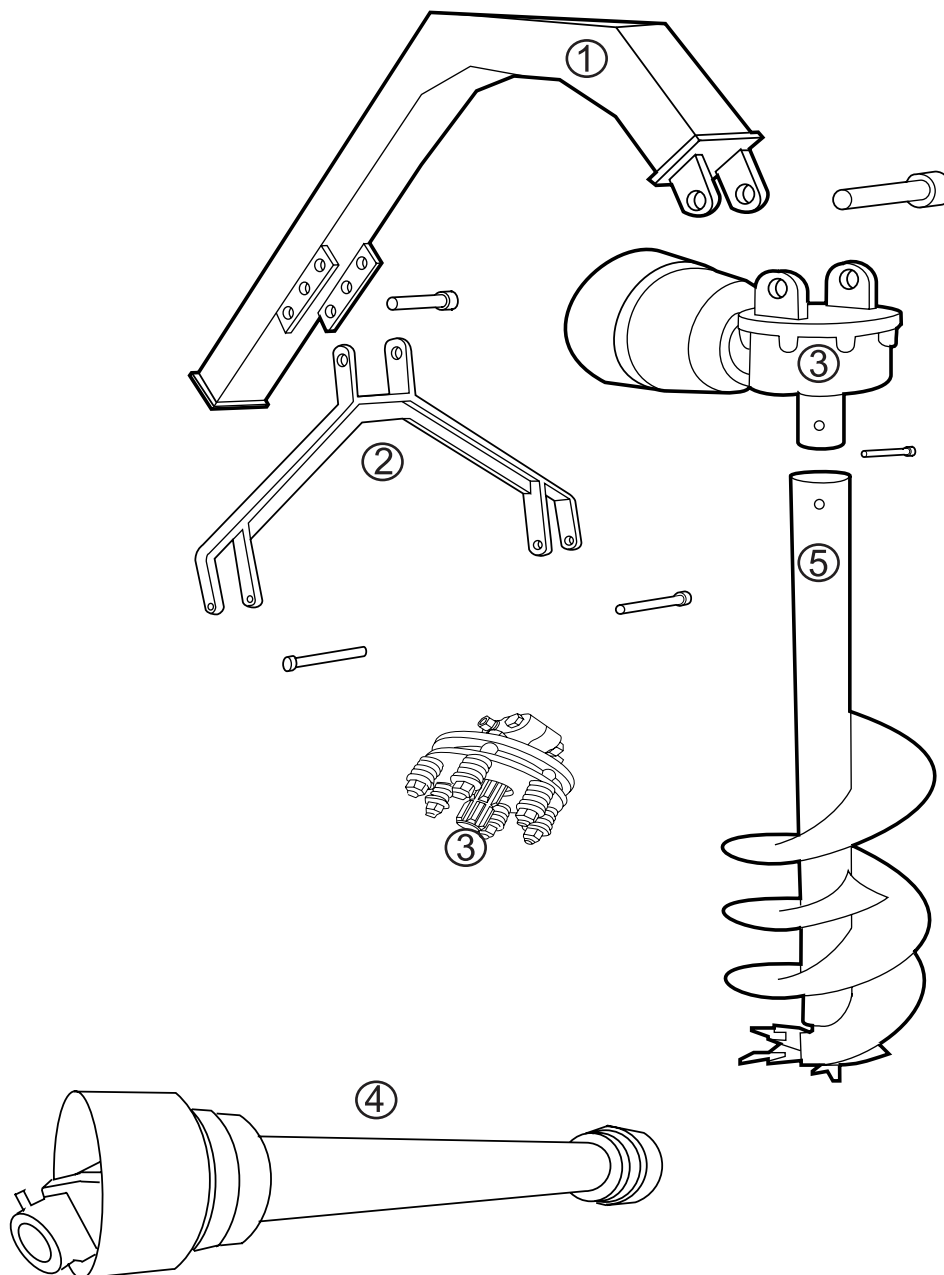

OPERATION

2.1 ASSEMBLY

2.1.1 Attaching to the Tractor

Standard Model

- i) Attach the main support boom to the top link of the tractor with a cat 1 top link pin.
- ii) Connect the 'A' frame to the lower link arms of the tractor with cat 1 lower link pins.
- iii) Position and connect the top of the 'A' frame with the outer pivot hole (pivot hole furthest from the tractor) under the main boom.
- iv) Using the hydraulic linkage of the tractor, check the range of movement by raising and lowering the boom. Moving the pivot pin closer to the tractor will increase the height the boom will lift.
- v) With the boom positioned at a convenient height, attach the gear box (with the input shaft facing the tractor) to the boom by aligning the holes and inserting the mounting pin.
- vi) Check the length of the PTO drive shaft by separating the telescopic shaft and attaching one section to the tractor PTO and the other to the digger gear box. Hold both sections together and parallel. Lower the main boom so the the gearbox input stub is horizontal with the PTO out put stub. Ensure the PTO shaft has a clearance of at least 150mm. Repeat the process at the maximum lift height of the boom. Ensure the PTO shafts has at least 300mm overlap. This operation will determine the correct operating length of the drive shaft. The shaft may need to be cut to size.
- vii) Connect the auger to the output shaft of the gear box with the two shear pins. Tighten the nuts securely.
- viii) Connect the drive shaft to the gear box and other end to the tractor PTO ensuring correct alignment and seating of the locking pin.
- viii) Raise and lower the linkage carefully to ensure sufficient ground clearance can be maintained. Adjust the 'sway chains' to provide minimal side-ways movement.

Hydraulic Model

First fit up:

- i) Fit the post hole digger boom and 'A' frame to the three point linkage with the ram disconnected at the ram end.
- ii) Select the 'A' frame and boom pivot position to suit the tractor. You will need the boom to raise high enough to clear the surface with the auger tip by 100 – 150mm, and lower enough to dig the required depth.
- iii) Fit the auger and lower the auger tip to rest firmly on the ground.
- iv) **Place the linkage lever in the full down position and do not move it at any time.**
- v) Check the PTO shaft for length as described in vi) above. Cut the shaft to suit as necessary following the safety precautions described earlier.
- vi) Pin the hydraulic ram to the mount on the boom. Ensure all pins are locked securely.

The hydraulic remote lever is the only control now used to raise and lower the auger.

OPERATION

2.1.2 Attaching the Assembled Digger to the Tractor

- i) Position the digger with the PTO shaft removed and gearbox and auger on the ground behind the boom.
- ii) Back the tractor into position and lower the linkage. Connect the tractor lower linkage to the 'A' frame.
- iii) Align and connect the main boom top link mount to the tractor.
- iv) Lift the main boom with the hydraulics to the right height and fit the gear box and auger to the end of the boom.
- v) Fit the PTO shaft.
- vi) Make sure the safety guards are in place and properly secured

2.1.3 Changing Auger Teeth and Pilot

When worn the teeth and/or pilot bit on the auger should be replaced to maintain good digging performance.

Two types of teeth and pilots are available. Standard teeth and standard pilot are used for normal ground conditions. Hard-faced teeth and hard-faced pilot can be fitted for drilling in rocky ground. Both types of teeth and pilots will fit the augers.

The teeth are located in the socket of the auger head by their 'U' shaped profile and are held in place by a rubber retainer which is wedged between the tooth and the socket. To remove the tooth, place a small punch on the rear corner and strike it sharply with a hammer to drive it out of the socket, refer to the diagram below.

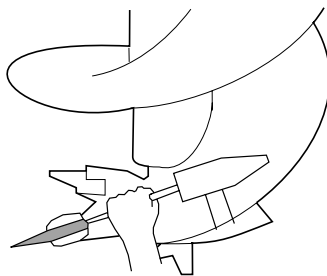

CAUTION: Always wear eye protection when installing and removing teeth

2.1.4 Changing the Auger

All augers are the same length and are attached in the same way by two shear bolts through the gearbox output shaft.

To remove the auger, raise the boom to allow the auger to hang vertically then lower until the end of the auger is about 100mm above the ground. Stop the tractor engine and apply the parking brake. Remove the two attaching bolts from the upper end of the auger and pull down so that it slides off the gearbox shaft. If the auger is tight on the shaft loosen it by sharply striking the auger tube with a hammer where it overlaps the gearbox shaft. If it is necessary to strike the auger longitudinally on the flighting to drive it off the shaft, first place a piece of timber on the flighting to avoid damage.

OPERATION

Clean and lightly grease the gearbox output shaft and the inner tube of the new auger. Align the bolt holes and slide the auger onto the gearbox shaft. Install and securely tighten the two shear bolts.

2.1.5 Detaching the Digger from the Tractor

Raise the boom to allow the auger to hang vertically then lower it until the end rests on the ground. Stop the tractor engine and apply the parking brake. Remove the PTO shaft. Move the tractor slowly forward whilst lowering the boom until the digger gearbox rests on the ground. Stop the tractor and fully lower the linkage. Disconnect the upper linkage pin then the lower pins. It may be necessary to use a hoist to take the weight of the digger.

Alternatively the digger can be removed with the PTO still attached to the gearbox by drilling the auger into the ground, to hold it in an upright position.

2.2 General Operation

Standard Model

Before operating the digger for the first time carry out the lubrication checks. Check the gearbox oil level and grease the PTO drive shaft universal joints and telescoping shaft. Read all the safety information contained in this manual and on the decals attached to the machine. Carefully inspect the area to be dug.

In very good digging conditions the auger can sometimes cork-screw into the ground without breaking out the soil. Avoid this happening by periodically lifting the auger with the three point linkage enough to break the drilled ground. In most instances this will not be required.

- **Always operate the digger from the tractor seat. Under no circumstances stand or allow any other person to stand near the auger when it is revolving. Never clear earth or allow any other person to clear earth from the auger while it is revolving. No other person should be within ten meters of the machine while it is in operation.**

Position the tractor with the auger hanging vertical and touching the ground at the spot where the hole is to be dug. Use the tractor linkage to raise or lower the auger. Move the tractor backwards and forwards and adjust the three point linkage vertical arm to get the auger perpendicular. Set the tractor engine speed to a fast idle so that the auger will revolve in the range of 50 to 100 rpm. The most appropriate auger speed will depend upon the available tractor power, the diameter of the auger and the ground conditions. The larger the diameter of the auger the slower the auger should rotate.

Engage the PTO drive and allow the action of the auger to penetrate the surface.

Slowly lower the tractor linkage to follow the penetration of the auger.

At every 300 to 500mm of depth lift the boom to spin the earth off the auger flighting, and then continue drilling. When lifting, do not lift the auger clear of the hole as the auger will angle back and may not track back into the hole. At stages of drilling you may need to move the tractor forward or backward to keep the auger vertical and compensate for the arc of the boom.

If the safety clutch slips reduce the 'down pressure' and if necessary inspect the hole for obstructions.

OPERATION

Before inspecting the hole or when the required depth has been reached, raise the auger from the hole and disengage the PTO drive. Move the tractor away from the hole and lower the auger so that the end rests on the ground. **Stop the tractor engine, apply the parking brake and dismount to inspect the hole.**

When transporting the post hole digger, raise the auger and travel slowly at a speed that is safe for the particular ground or road conditions. If traveling on a public road, ensure that the tractor complies with the local regulations.

Hydraulic Model

Follow all safety precautions. To use the hydraulic post hole digger effectively, some experience with remote hydraulics is helpful.

- Position the auger where the hole is to be dug and ensure it is vertical
- Engage the PTO in 540 rpm and select mid throttle.
- **Lower the auger slowly using the hydraulics until it starts to dig. Continue to lower the auger slowly ensuring it does not corkscrew into the ground. It may be necessary to clear the auger by raising it from time to time, only using the remote control lever. When the required depth is reached, lift the auger with the hydraulic remotes and move to the next hole.**

SERVICE AND MAINTENANCE

3.1 Service

3.1.1 FLUIDS AND LUBRICANTS

1. Grease:
Use multi-purpose lithium based grease.
2. Gear Box Oil:
Use 80W90 Gear oil.
3. Storing Lubricants:
Your machine can operate at top efficiency only if clean lubricants are used. Use clean containers to handle all lubricants. Store them in an area protected from dust, moisture and other contaminants.

3.1.2 GREASING

1. Use a hand-held grease gun for all greasing.
2. Wipe grease nipple with a clean cloth before greasing, to avoid injecting dirt and grit.
3. Replace and repair broken nipples immediately.
4. If nipples will not take grease, remove and clean thoroughly. Also clean lubricant passageway. Replace nipple if necessary.

3.2 Maintenance

The recommended period is based on normal operating conditions. Severe or unusual conditions may require more frequent maintenance.

3.2.1 8 HOURS OR DAILY MAINTENANCE

- 1 Check and tighten all bolts and auger teethes.
- 2 Check the oil in gearbox. Fill up to line if it's necessary.
- 3 Pump grease into each grease nipple three to five times.
- 4 Clean the implement; take away all grass and mud.

3.2.2 SEASON MAINTENANCE

- 1 Check the machine as above for daily maintenance.
- 2 Check Auger tooth rubber tightener, replace if required
- 2 Check the oil in gearbox; replace it if it is contaminated.

3.2.3 ANNUAL MAINTENANCE

- 1 Thoroughly clean the Post hole digger of mud and grass.
- 2 Drain the gearbox and clean it thoroughly. Fill with new gear oil up to the dedicated oil level.
- 3 Check and clean Auger head and teethes . Replace if warn out or damaged.
- 4 Remove the drive shaft from the machine. Pull the PTO shaft apart. Check and replace any components that are damaged or worn. Install the PTO shaft on the machine. The PTO shaft should telescope easily and the guard turn freely on the shaft

SERVICE AND MAINTENANCE

	8hrs/ Daily			40hrs/Weekly			Annually		
Lubricate PTO Shaft	✓			✓			✓		
Check Gear Box Oil Level				✓			✓		
Clean Machine							✓		
Lubricate and Clean PTO Shaft Cover							✓		

3.2.4 PTO SHAFT MAINTENANCE

The PTO shaft is designed to telescope to allow for dimensional changes as the machine goes through its operating range. A tubular guard encloses the driving components and is designed to remain stationary on a turning shaft when required. The shaft should telescope easily and the guard turn freely on the shaft at all times. Annual disassembly, cleaning and lubrication is recommended to insure that all components function as intended. To maintain the shaft, follow this procedure:

1. Remove the shaft from the machine.
2. Pull shaft apart.
3. Use a screwdriver to pry the tabs out of the sleeves on each end. There are 3 tabs per guard.
4. Pull the shaft out of the plastic tubular guard.
5. Use a solvent to clean the male and female portions of the telescoping ends.
6. Apply a light coat of grease to each end.
7. Clean grooves on each end where the tabs are located. Clean each tab also.
8. Apply a light coat of grease to each groove.
9. Insert the shaft into its respective guard and align the slots with the groove.
10. Insert the tabs through the slots and seat in the groove.
11. Check that each guard turns freely on the shaft.
12. Assemble the shaft.
13. Check that the shaft telescopes easily.
14. Replace any components that are damaged or worn.
15. Install the shaft on the machine.

3.2.5 GEARBOX MAINTENANCE

The gearbox used on the Post hole digger will give many years of trouble-free service with minimal maintenance requirements. Maintain the gearbox by following this procedure:

Oil level:

- Remove the level plug from the rear or side of the gearbox.
- Add oil through the filler plug located on top of gearbox until oil comes out of level plug.
- Add through the fill plug if required.
- If gearbox has a dipstick on filler plug, then fill to indicator mark.

IMPORTANT: Check the oil level only when the unit is cold and the machine is on the level.

SERVICE AND MAINTENANCE

3.3 STORAGE

After the season's use, the machine should be thoroughly inspected and prepared for storage. Repair or replace any worn or damaged components to prevent any unnecessary down time at the start of next season. To insure a long, trouble free life, follow the procedure outlined below:

1. Thoroughly wash the machine using a pressure washer to remove all dirt, mud, debris and residue.
2. Inspect the blades and rotor for damage or entangled material. Repair or replace damaged parts. Remove all entangled material.
3. Lubricate all grease nipples. Make sure that all grease cavities have been filled with grease to remove any water residue from the inside.
4. Touch up all paint nicks and scratches to prevent rusting.
5. Move to storage area.
6. Select an area that is dry, level and free of debris.
7. Unhook from tractor (see Section 2.4).
8. If the machine cannot be placed inside, cover with a waterproof tarpaulin and tie securely in place.

Store the machine in an area away from human activity. Do not allow children to play on or around the stored machine.

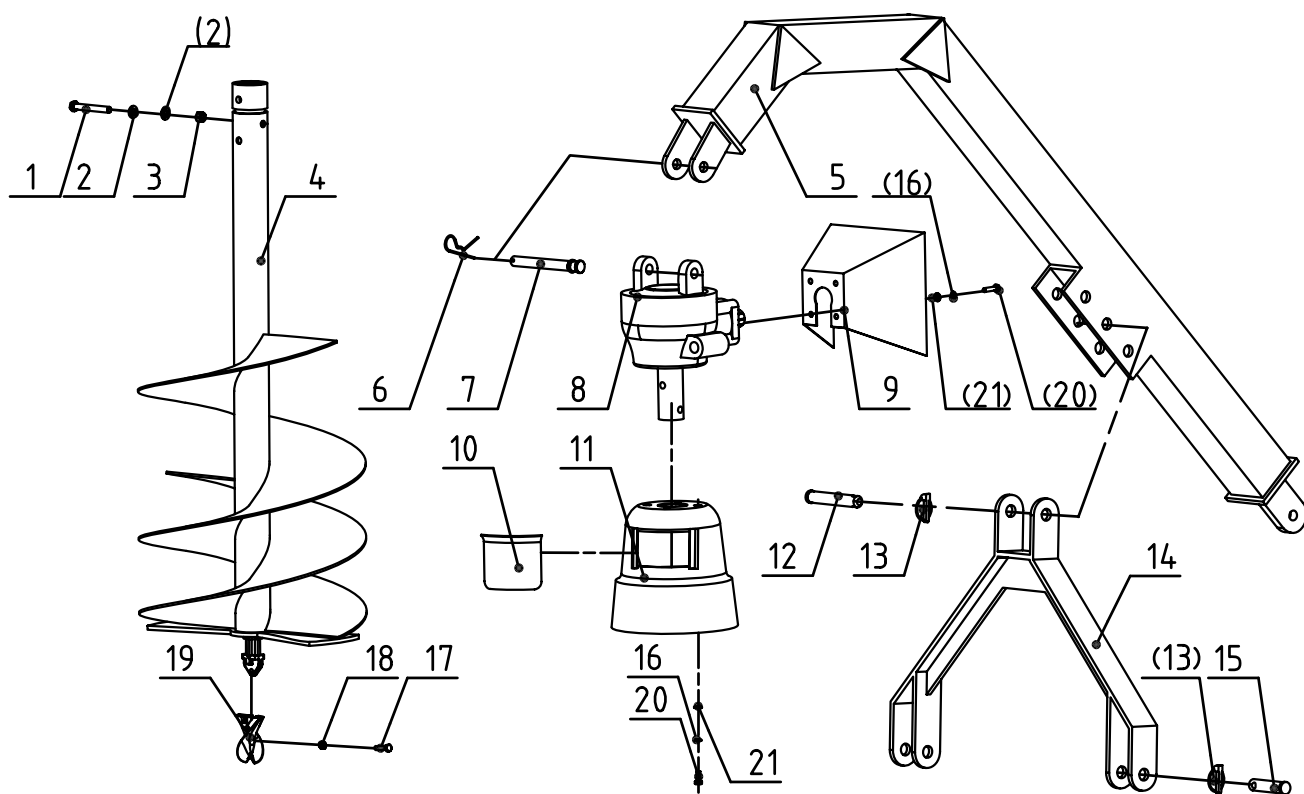

21	GB97.1-86	Plain washer 8	8	
20	GB5783-89	Bolt M8X20	8	
19	HHDG-18.108	Aiguille	1	
18	GB6184-87	Lock nut M8	1	
17	GB5783-86	Bolt M8X40	1	
16	GB93-87	Spring lock washer 8	8	
15	HHDG-18.103	Lower hanging pin	2	
14	HDG-18.011	Hanging bracket	1	
13		Lock pin	3	
12	HDG-18.102	Safety pin	1	
11	HHDG-18.101	Shield of tool bar	1	
10	HHDG-18.102	Cap	1	
9	HHDG-18.014	Shield Of Gear box	1	
8		Gear box	1	
7	HHDG-18.106	Joint pin of gear box	1	
6		R pin	1	
5	HDG-18.012	Lifting bracket	1	
4	HHDG-18.013	Tool bar	1	
3	GB6184-87	Lock nut M12	2	
2	GB97.1-86	Plain washer 12	4	
1	GB5782-87	Bolt M12X90	2	
No	Part Number	Description		