



**HYDRAULIC REACH
TRIMMER
HRT160
OPERATION MANUAL**



Agpro Australia Pty Ltd

3730 Harmony Way

Harcourt

Vic 3453

1300 121 131

agpro@agproproducts.com.au

DECLARATION OF CONFORMITY

Declare under our responsibilities that the machine:

Hydraulic reach trimmer

Model.....

Serial number.....Year.....

Complies with the following European Directive:

98/37/EC (that abrogates and includes the Directives 89/392/EEC, 91/368/EEC, 93/44/CEE and 93/68/EEC)

For the machine adaptation, the following harmonized standards have been used:

EN ISO 4254-1 2005

EN 745 1999

As well as the technical specification :

ISO 11684 1995

Montechiaro d'Asti (AT),

The legal representative

AGPRO wants to thank you for having chosen one of its products.

The technological evolution and the new request of the agricultural world have pushed our firm to a continued improvement, focused on the product, on the quality of the materials and on the quality of work.

The present manual contains the description of the machine and the necessary instructions to correctly use it, along with the instructions for an ordinary and periodic maintenance of the shredder.

Such manual is subdivided in easily recognizable chapters for a practical consultation.

The indications in the present manual are addressed to a professional user, who must have specific knowledge about the driving modalities of the tractor with which the machine is connected. The user has to be authorized, instructed and opportunely trained.

We recommend you to use only original spare parts and accessories.

The use of non-original parts could be dangerous reducing the duration and the performances of the machine as well as the decay of the warranty.

In the case of doubt about the interpretation of the subjects illustrated in this handbook, we suggest you to contact the dealer who will be ready to assist you whenever you need it.

I GENERAL INFORMATION



This Operator's Manual is an integral part of the safe operation of this machine and must be maintained with the unit at all times. **READ, UNDERSTAND, and FOLLOW** the Safety and Operation Instructions contained in this manual before operating the equipment.

I.i information about the manual

The using prescriptions shown in this Handbook must be carefully observed to obtain the best performances, to assure the greatest duration of the different parts and to avoid damages to the machine and accidents to the operator.

It is advised the careful reading of the present handbook, to deepen the knowledge of the SHREDDER, before starting to use it.

The present manual is to be considered an integral part of the machine, it must go with the machine in case of resale and till its demolition.

Some illustrations in this manual show particulars or accessories that could be different from those of your machine, some component could have been removed to assure the clearness of the illustrations.

The subjects dealt in this handbook are those expressly requested by the "CE/98/37directive" and by the relatives technical standards.

On the machine are inserted apposite pictograms, which the operator will take care to maintain in perfect visual state and to replace when they are not more readable.



This symbol with the under indicated words:

DANGER
ATTENTION
WARNING

is used in this handbook to draw Your attention on the safety and the good working of the machine. So it is necessary to observe all the indicated rules.

This Handbook has been written following the effective regulations at the moment of its printing. It is an integral part of the machine and must go with the machine with the Declaration of Conformity in case of resale.

Operator Safety Instructions and Practices

WARNING: Engine Exhaust, some of its constituents, and certain vehicle components contain or emit Chemicals.

WARNING: Battery posts, terminals and related accessories contain lead and lead compounds, chemicals known to the state of California to cause cancer, birth defects or other reproductive harm. (SG-31)

WARNING: The rotating parts of this machine continue to rotate even after the PTO has been turned off. The operator should remain in his seat for 60 seconds after the brake has been set, the PTO disengaged, the tractor turned off, and all evidence of rotation has ceased.

WARNING: Never crawl under a raised Implement supported solely by the Tractor 3-Point hitch. Release of the control lever or mechanical failure will result in the Implement falling and possible injury or death. Always securely block up the Implement before crawling underneath to perform repairs and service.

WARNING: Never operate the Tractor or Implement until you have read and completely understand this Manual, the Tractor Operator's Manual, and each of the Safety Messages found in the Manual or on the Tractor and Implement. Learn how to stop the tractor engine suddenly in an emergency.

Safety notes

WARNING: Never allow inexperienced or untrained personnel to operate the Tractor and Implement without supervision. Make sure the operator has fully read and understood the manuals prior to operation. The operator and all support personnel should wear hard hats, safety shoes, safety glasses, and proper hearing protection at all times for protection from injury including injury from items that may be thrown by the equipment.

CAUTION PROLONGED EXPOSURE TO LOUD NOISE MAY CAUSE PERMANENT HEARING LOSS! Tractors with or without an Implement attached can often be noisy enough to cause permanent hearing loss. We recommend that you always wear hearing protection if the noise in the Operator's position exceeds 80db. Noise over 85db over an extended period of time will cause severe hearing loss. Noise over 90db adjacent to the Operator over an extended period of time will cause permanent or total hearing loss. **NOTE:** *Hearing loss from loud noise [from tractors, chain saws, radios, and other such sources close to the ear] is cumulative over a lifetime without hope of natural recovery*

DANGER KEEP AWAY FROM ROTATING ELEMENTS to prevent entanglement and possible serious injury or death. Never allow children to play on or around Tractor or Implement. Children can slip or fall off the Equipment and be injured or killed. Children can cause the Implement to shift or fall crushing themselves or others. (

DANGER NEVER use drugs or alcohol immediately before or while operating the Tractor and Implement. Drugs and alcohol will affect an operator's alertness and coordination and therefore affect the operator's ability to operate the equipment safely. Before operating the Tractor or Implement, an operator on prescription or over-the-counter medication must consult a medical professional regarding any side effects of the medication that would hinder their ability to operate the Equipment safely.

DANGER NEVER knowingly allow anyone to operate this equipment when their alertness or coordination is impaired. Serious injury or death to the operator or others could result if the operator is under the influence of drugs or alcohol.

Prolonged operation may cause operator boredom and fatigue affecting safe operation. Take scheduled work breaks to help prevent these potentially impaired operating conditions. Never operate the Implement and Tractor in a fatigued or bored mental state which impairs proper and safe operation.

WARNING Use extreme caution when getting onto the Implement to perform repairs, maintenance and when removing accumulated material. Only stand on solid flat surfaces to ensure good footing. Use a ladder or raised stand to access high spots which cannot be reached from ground level. Slipping and falling can cause serious injury or death.

WARNING Avoid contact with hot surfaces including hydraulic oil tanks, pumps, motors, valves and hose connections. Relieve hydraulic pressure before performing maintenance or repairs. Use gloves and eye protection when servicing hot components. Contact with a hot surface or fluid can cause serious injury from burns or scalding. (

DANGER DO NOT operate this Implement on a Tractor that is not properly maintained. Should a mechanical or Tractor control failure occur while operating, immediately shut down the Tractor and perform repairs before resuming operation. Serious injury and possible death could occur from not maintaining this Implement and Tractor in good operating condition.

WARNING Avoid contact with hot surfaces of the engine or muffler. Use gloves and eye protection when servicing hot components. Contact with a hot surface or fluid can cause serious injury from burns or scalding.

Do not put hands or feet under mower decks. Blade Contact can result in serious injury or even death. Stay away until all motion has stopped and the decks are securely blocked up.

DANGER Always keep a careful lookout and use extreme care when working around utility and municipal obstructions. Never allow the Mower to contact any utility, municipal, or other type structure. Clearly mark all mowing obstructions and consult local utility providers for a safe code of operation.

DANGER Do not operate the implement while wearing loose fitting clothing. Entanglement of the clothing with the rotating elements can result in serious injury or even death. Stay clear of all rotating elements at all times.

Equipment Operation Safety Instructions and Practices

WARNING Never leave the Tractor and Implement unattended while the Implement is in the lifted position. Accidental operation of lifting lever or a hydraulic failure may cause sudden drop of unit with injury or death by crushing. To properly park the implement when disconnecting it from the tractor, lower the stand and put the retaining pin securely in place, or put a secure support under the A-Frame. Lower the implement carefully to the ground. Do not put hands or feet under lifted components.

WARNING Use extreme care when lowering or unfolding the implement's wings. Make sure no bystanders are close by or underneath the wings. Allow ample clearance around the implement when folding or unfolding the wings. Use extreme caution around buildings or overhead power lines.

DANGER This Implement is wider than the Tractor. Be careful when operating or transporting this equipment to prevent the Implement from running into or striking sign posts, guard rails, concrete abutments or other solid objects. Such an impact could cause the Implement and Tractor to pivot violently resulting in loss of steering control, serious injury, or even death. Never allow the Implement to contact obstacles.

DANGER Be sure you have adequate knowledge of the property you will be working on. Take time to make yourself aware of any area underground lines or cables. Contact with buried lines or cable could result in **serious injury or death**

WARNING Do not operate Mower if excessive vibration exists. Shut down PTO and the Tractor engine. Inspect the Mower to determine the source of the vibration. If Mower blades are missing or damaged replace them immediately. Do not operate the mower until the blades have been replaced and the Mower operates smoothly. Operating the Mower with excessive vibration can result in component failure and broken objects to be thrown outward at very high velocities. To reduce the possibility of property damage, serious injury, or even death, never allow the Mower to be operated with blades missing. (SFL-4)

WARNING Operate this Equipment only with a Tractor equipped with an approved rollover-protective system (ROPS). Always wear seat belts. Serious injury or even death could result from falling off the tractor--particularly during a turnover when the operator could be pinned under the ROPS.

DANGER BEFORE leaving the tractor seat, always engage the brake and/or set the tractor transmission in parking gear, disengage the PTO, stop the engine, remove the key, and wait for all moving parts to stop. Place the tractor shift lever into a low range or parking gear to prevent the tractor from rolling. Never dismount a Tractor that is moving or while the engine is running. Operate the Tractor controls from the tractor seat only.

DANGER Never allow children or other persons to ride on the Tractor or Implement. Falling off can result in serious injury or death

DANGER Never allow children to operate, ride on, or come close to the Tractor or Implement.

Do not mount or dismount the Tractor while the tractor is moving. Mount the Tractor only when the Tractor and all moving parts are completely stopped. (SG-12)

DANGER Start tractor only when properly seated in the Tractor seat. Starting a tractor in gear can result in injury or death. Read the Tractor operators manual for proper starting instructions. (SG-13)

DANGER Do not operate this Equipment with hydraulic oil or fuel leaking. Oil and fuel are explosive and their presence could present a hazard. Do not check for leaks with your hand! High-pressure oil streams from breaks in the line could penetrate the skin and cause tissue damage including gangrene. To check for a hose leak, SHUT the unit ENGINE OFF and remove all hydraulic pressure. Wear oil impenetrable gloves, safety glasses and use Cardboard to check for evidence of oil leaks. If you suspect a leak, REMOVE the HOSE and have it tested at a Dealer. If oil does penetrate the skin, have the injury treated immediately by a physician knowledgeable and skilled in this procedure. (SG-15)

DANGER Never run the Tractor engine in a closed building or without adequate ventilation. The exhaust fumes can be hazardous to your health. (SG-23)

DANGER Do not exceed the rated PTO speed for the Implement. Excessive PTO speeds can cause Implement driveline or blade failures resulting in serious injury or death.

WARNING Operate the Tractor and/or Implement controls only while properly seated in the Tractor seat with the seat belt securely fastened around you. Inadvertent movement of the Tractor or Implement may cause serious injury or death.

WARNING In case of mechanical difficulty during operation, place the transmission in the park position, set the parking brake, shut down all power, including the PTO and the engine and remove the key. Wait until all rotating motion has stopped before dismounting.

DANGER Do Not operate this equipment in areas where insects such as bees may attack you and/or cause you to lose control of the equipment. If you must enter in such areas, use a tractor with an enclosed Cab and close the windows to prevent insects from entering. If a tractor cab is not available, wear suitable clothing including head, face, and hand protection to shield you from the insects. Attacking insects can cause you to lose control of the tractor, which can result in serious injury or death to you or bystanders. Never dismount a moving tractor.

DANGER Mow only in conditions where you have clear visibility in daylight or with adequate artificial lighting. Never mow in darkness or foggy conditions where you cannot clearly see at least 100 yards(90 m) in front and to the sides of the tractor and mower. Make sure that you can clearly see and identify passersby, steep slopes, ditches, drop-offs, overhead obstructions, power lines, debris and foreign objects. If you are unable to clearly see these type of items discontinue mowing

DANGER There are obvious and hidden potential hazards in the operation of this Mower. REMEMBER! This machine is often operated in heavy brush and in heavy weeds. The Blades of this Mower can throw objects if shields are not properly installed and maintained. Serious injury or even death may occur unless care is taken to insure the safety of the operator, bystanders, or passersby in the area. Do not operate this machine with anyone in the immediate area. Stop mowing if anyone is within 100 yards of mower

DANGER The rotating parts of this machine have been designed and tested for rugged use. However, the blades could fail upon impact with heavy, solid objects such as metal guard rails and concrete structures. Such impact could cause the broken objects to be thrown outward at very high velocities. To reduce the possibility of property damage, serious injury, or even death, never allow the cutting blades to contact such obstacles.

WARNING Extreme care should be taken when operating near loose objects such as gravel, rocks, wire, and other debris. Inspect the area before mowing. Foreign objects should be removed from the site to prevent machine damage and/or bodily injury or even death. Any objects that cannot be removed must be clearly marked and carefully avoided by the operator. Stop mowing immediately if blades strike a foreign object. Repair all damage and make certain rotor or blade carrier is balanced before resuming mowing.

WARNING Many varied objects, such as wire, cable, rope, or chains, can become entangled in the operating parts of the mower head. These items could then swing outside the housing at greater velocities than the blades. Such a situation is extremely hazardous and could result in serious injury or even death. Inspect the cutting area for such objects before mowing. Remove any like object from the site. Never allow the cutting blades to contact such items.

DANGER Mow at the speed that you can safely operate and control the tractor and mower. The correct mowing speed depends on terrain condition and grass type, density, and height of cut. Normal ground speed range is from 2 to 5 mph(3-8 kph). Use slow mowing speeds when operating on or near steep slopes, ditches, drop-offs, overhead obstructions, power lines, or when debris and foreign objects are to be avoided. Avoid mowing in reverse direction when possible. Check to make sure there are no persons behind the mower and use extreme care when mowing in reverse. Mow only at a slow ground speed where you can safely operate and control the tractor and mower. Never mow an area that you have not inspected and removed debris or foreign material.

DANGER Do not mow with two machines in the same area except with Cab tractors with the windows closed

WARNING Follow these guidelines to reduce the risk of equipment and grass fires while operating, servicing, and repairing the Mower and Tractor:

- Equip the Tractor with a fire extinguisher in an accesible location.
- Do Not operate the Mower on a Tractor with an underframe exhaust.

- Do Not smoke or have an open flame near the Mower and Tractor.
 - Do Not drive into burning debris or freshly burnt areas.
 - Ensure slip clutches are properly adjusted to prevent excessive slippage and plate heating.
 - Never allow clippings or debris to collect near drivelines, slip clutches, and gearboxes.
- Periodically shut down the Tractor and Mower and clean clippings and collected debris from the mower deck.

The Mower is designed for certain mowing applications and is rated to cut up to a specific size vegetation (see Mower Standard Equipment and Specifications). DO NOT use this mower to cut vegetation above the Mower's rated capacity or to cut any type of nonvegetative material. Only operate this Mower on a properly sized and equipped Tractor.

Operating this Mower in an application for which it is not designed and/or operating the Mower with the wrong size Tractor can cause Mower component damage and equipment failure resulting in possible serious injury or death. (SGM-14)

Do not operate or pull the mower into standing water. When uplift or fan type mower blades contact water they can be severely deflected downward causing possible failure of blade resulting in serious injury to the operator or bystanders. (SGM-15)

Use extreme caution when raising the Mower above ground level. Stop the Blades from turning when the Mower is raised and passersby are within 100 yards. Raising the Mower exposes the Cutting Blades which creates a potentially serious hazard and can cause serious injury by objects thrown from the Blades or by contact with the Blades.

Connecting or Disconnecting Implement Safety Instructions and Practices

Rotary Mowers are capable under adverse conditions of throwing objects for great distances (300 feet or more) and causing serious injury or death. Follow safety messages carefully.

STOP MOWING IF PASSERSBY ARE WITHIN 100 YARDS UNLESS:

- Front and Rear Deflectors, Chain Guards, or Bands are installed and in good, workable condition;
- Mower sections or Wings are running close to and parallel to the ground without exposed Blades;
- Passersby are outside the existing thrown-object zone;
- All areas have been thoroughly inspected and all foreign material such as rocks, cans, glass, and general debris has been removed.

NOTE: *Where there are grass and weeds high enough to hide debris that could be struck by the blades, the area should be: inspected and large debris removed, mowed at an intermediate height, inspected, closely with any remaining debris being removed, and mowed again at desired final height. (This will also reduce power required to mow, reduce wear and tear on the Mower drivetrain, spread cut material better, reduce streaking, and make the final cut more uniform).* (SRM-01)

WARNING Do not turn so sharp or lift mower so high to produce a severe "knocking" of the Driveline which will cause accelerated wear and breakage of drive train components and could result in possible injury from the separated Driveline sections. (SRM-04)

Do not let the Blades turn when the Mower Deck is raised for any reason, including clearance or for turning. Raising the Mower deck exposes the Cutting Blades which creates a potentially serious hazard and could cause serious injury or even death from objects thrown from the Blades.

DANGER DO NOT use a PTO adapter to attach a non-matching Implement driveline to a Tractor PTO. Use of an adapter can double the operating speed of the Implement resulting in excessive vibration, thrown objects, and blade and implement failure. Adapter use will also change the working length of the driveline exposing unshielded driveline areas. Serious bodily injury and/or equipment failure can result from using a PTO adapter. Consult an authorized dealer for assistance if the Implement driveline does not match the Tractor PTO.

Transporting Safety Instructions and Practices

Always shut the Tractor completely down, place the transmission in park, and set the parking brake before you or anyone else attempts to connect or disconnect the Implement and Tractor hitches

WARNING Never operate the Tractor and Mower if the Implement input driveline is directly connected to the Tractor transmission. Tractor braking distances can be substantially increased by the momentum of the rotating Mower blades driving the Tractor transmission even though the Tractor clutch has been disengaged. Install an over running clutch between the Tractor PTO and the Mower driveline to prevent this potentially dangerous situation.

When attaching the Implement input driveline to the Tractor PTO, it is important that the connecting yoke spring activated locking collar slides freely and the locking balls are seated securely in the groove on the Tractor PTO shaft. Push and pull the driveline back and forth several times to ensure it is securely attached. A driveline not attached correctly to the Tractor PTO shaft could come loose and result in personal injury and damage to the Implement.

WARNING Before operating the Implement, check to make sure the Implement input driveline will not bottom out or become disengaged. Bottoming out occurs when the inner shaft penetrates the outer housing until the assembly becomes solid-it can shorten no more. Bottoming out can cause serious damage to the Tractor PTO by pushing the PTO into the Tractor and through the support bearings or downward onto the PTO shaft, breaking it off. A broken driveline can cause personal injury.

WARNING Be particularly careful when transporting the Implement with the Tractor. Turn curves or go up hills only at a low speed and using a gradual steering angle. Rear mounted implements move the center of gravity to the rear and remove weight from the front wheels. Make certain, by adding front ballast, that at least 20% of the tractor's weight is on the front wheels to prevent rearing up, loss of steering control or Tractor tip-over. Slow down on rough or uneven surfaces to prevent loss of steering control which could result in property damage or possible injury. Do not transport unless 3-Point lift lever is fully raised and in the latched transport position. Dropping implement in transport can cause serious damage to the tractor and/or Implement and possibly cause the operator or others to be injured or killed.

WARNING Allow sufficient clearance for the Implement to swing outward while turning. Implements carried behind the Tractor will swing outside the tire path when making turns. Contacting a solid object while turning will cause equipment damage and possible injury. (S3PT-20)

WARNING Be aware of the operating conditions. Do not operate the Tractor with weak or faulty brakes or worn tires. When operating down a hill or on wet or rain slick roads, the braking distance increases: use extreme care and reduce your speed. When operating in traffic always use the Tractor's flashing warning lights and reduce your speed. Be aware of traffic around you and watch out for the other guy.

Be particularly careful when transporting the Implement using the tractor. Turn curves or go up or down hills only at a low speed and at a gradual steering angle. Make certain that at least 20% of the tractor's weight is on the front wheels to maintain safe steering. Slow down on rough or uneven surfaces.

Maintenance and Service Safety Instructions and Practices

Your driving vision may be reduced or impaired by the tractor, cab, or implement. Before driving on public roadways identify any limited vision areas, and make adjustments to your operating position, mirrors, and the implement transport position so that you can clearly see the area where you will be traveling, and any traffic that may approach you. Failure to maintain adequate vision of the public roadway and traffic can result in serious injury or even death.

Make sure the PTO shield, integral driveline shields, and input shields are installed when using PTO-driven equipment. Always replace any shield if it is damaged or missing. Relieve hydraulic pressure prior to doing any maintenance or repair work on the Implement. Place the Implement on the ground or securely blocked up, disengage the PTO, and turn off the tractor engine. Push and pull the Remote Cylinder lever in and out several times prior to starting any maintenance or repair work.

WARNING Always disconnect the main PTO Driveline from the Tractor before performing service on the Implement. Never work on the Implement with the tractor PTO driveline connected and running. Rotating Parts, Blades or Drivelines could turn without warning and cause immediate entanglement, injury or death. (S3PT-11)







WARNING Always maintain the safety signs in good readable condition. If the safety signs are missing, damaged, or unreadable, obtain and install replacement safety signs immediately. (SG-5)

WARNING Do not modify or alter this Implement. Do not permit anyone to modify or alter this Implement, any of its components or any Implement function.

Never work under the Implement, the framework, or any lifted component unless the Implement is securely supported or blocked up to prevent sudden or inadvertent falling which could cause serious injury or even death.

Never attempt to lubricate, adjust, or remove material from the Implement while it is in motion or while tractor engine is running.

SPECIFICATIONS

Mod.		 HP		 OIL			A1	A2	B1	B2	C1	C2	 KG	
	CM	Min.	Max.	KGS	L	n°	RPM	°	°	°	CM	CM	CM	KGS
HRT160	160	25	40	1500	20		540	480	320	370	550	280	100	300

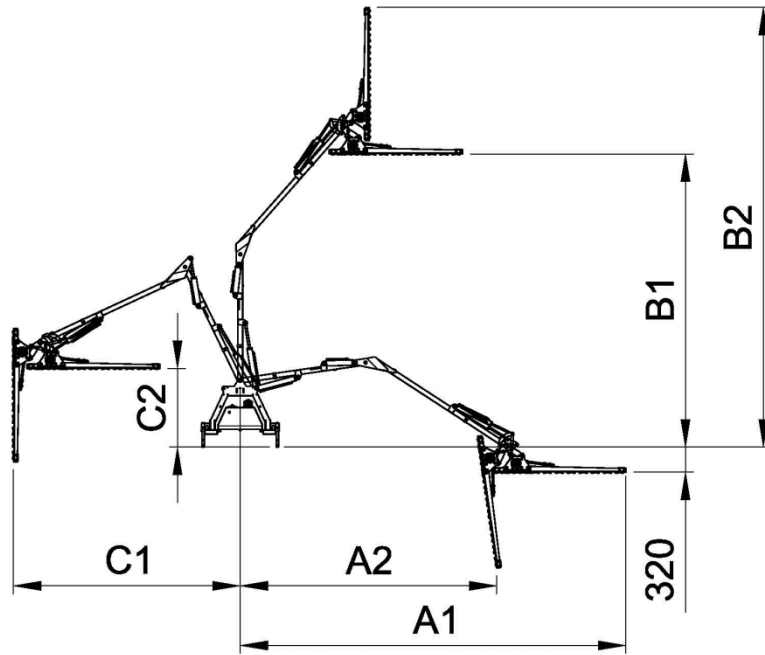

Warning Label



Label1

**ISTRUZIONI DI SICUREZZA · SICHERHEITSVORSCHRIFTEN
SAFETY INSTRUCTIONS · INSTRUCTIONS DE SECURITE**

I

- ALLONTANARE TUTTE LE PERSONE NON AUTORIZZATE DAL RAGGIO DI AZIONE DELLA MACCHINA OPERATRICE IN QUANTO CE PERICOLO DI LANCIO DI OGGETTI AD ALTA VELOCITA' PROVOCATI DAL MOVIMENTO DEGLI ORGANI ROTANTI DELLA MACCHINA
- MANTENERE LE PROTEZIONI SEMPRE IN POSIZIONE ED IN PERFETTO STATO DI EFFICIENZA TENERE LONTANO DAGLI ORGANI ROTANTI MANI, PIEDI, VESTITI, ETC.
- DISINSELERE SEMPRE LA PRESA DI FORZA PRIMA DI SCENDERE DAL TRATTORE
- NON CONSENTIRE A NESSUNA PERSONA NON QUALIFICATA O A BAMBINI DI AVVICINARSI ALLA MACCHINA
- NON LUBRIFICARE, PULIRE, AGGIUSTARE LA VOSTRA MACCHINA SENZA PRIMA AVER DISINNESTATO LA PRESA DI FORZA SPENTO IL TRATTORE E CHE GLI ORGANI ROTANTI IN MOVIMENTO SIANO COMPLETAMENTE FERMI
- CONTROLLATE SEMPRE IL SERRAGGIO DELLE VITI E DEI BULLONI DI SERRAGGIO DEGLI UTENSILI ROTANTI E DEL ROTORE PORTA MARTELLI
- ISPEZIONATE CON FREQUENZA LA MACCHINA PER VERIFICARE LA PRESENZA DI PARTICOLARI ALLENATI, SPECIALMENTE PRIMA DI INIZIARE IL LAVORO
- PRIMA DI INTRAPNDERE IL LAVORO RIMUOVERE DALL'AREA OPERATIVA EVENTUALI OGGETTI ESTRANEI E/O ROTTAMI DI FERRO
- QUANDO OPERATE IN TERRENI DECLIVI ASSICURATEVI DI OPERARE IN MASSIMA SICUREZZA EVITANDO CHE LE RUOTE SCIVOLINO DENTRO RUCHE, CANALI DI SCOLO, OSTACOLI CHE POTREBBERO PROVOCARE IL ROVESCIAMENTO DELLA TRATTRICE

D

- ENTFERNEN SIE ALLE PERSONEN AUS DEM GEFAHRENBEREICH DER MASCHINE, WELCHE NICHT DIREKT ZUM BETRIEB DER MASCHINE ERMACHTIGT SIND, DA DIE GEFAHR VON WURFESCHOSSEN GEGEBEN IST
- DIE SCHUTZVERKLEIDUNGEN SIND AUF IHRE FUNKTIONSTÜCHTIGKEIT HIN ZU ÜBERPRÜFEN, HALTEN SIE MIT ARMEN, FÜßEN UND KLEIDUNGSTÜCKEN DEN SICHERHEITSABSTAND EIN
- DIE KRAFTÜBERTRAGUNG BITTE IMMER LÖSEN, BEVOR SIE DEN TRAKTOR VERLASSEN
- VERMEIDEN SIE, DAS SICH UNBEFUGTE PERSONEN ODER KINDER IN DER NAHE DER ARBEITSGERÄTE AUFHALTEN
- NEHMEN SIE KEINE ABSETTEN AN DER MASCHINE VOR, BEVOR SIE NICHT DIE KRAFTÜBERTRAGUNG ABGESETZT HABEN, VERGESSEN SIE SICH AUCH, DAS ALLE BEWEGLICHEN TEILE DER MASCHINE STILLSTEHEN, ERST DANN SCHMIERN, WASCHEN ODER REPARIEREN SIE IHRE MASCHINE
- KONTROLLIEREN SIE LAUFEND DEN ANZUG DER SCHRAUBEN UND MUTTERN, WELCHE DIE BEWEGLICHEN TEILE DER ROTORWELLE ABSICHERN
- UNTERSÜHEN SIE IHRE MASCHINE REGELMÄßIGEN KONTROLLEN, UM EVT. LOSSE TEILE NOCH VOR ARBEITSBEGINN FESTZUSTELLEN UND ZU BEBEREN
- KONTROLLIEREN SIE VOR ARBEITSBEGINN DAS ZU BEARBEITENDE GELÄNDE AUF FREMDKÖRPER
- WENN SIE IN UNEBENEN GELÄNDE ARBEITEN WENDEN SIE DIE GRÖßTMÖGLICHE VORSICHT AN UM EIN DURCHDREHEN DER RADRE ODER EIN FESTSITZEN DERSELBEN ZU VERMEIDEN, DIES ALLES BIRGT NÄMLICH DIE GEFAHR EINES ÜBERSCHLAGS DER ZUGMASCHINE IN SICH ÜBERPRÜFEN SIE AUCH, OB DIE FÜR DAS GEWICHT GEEIGNETEN REIFEN AUFGEZOGEN SIND

GB

- MAKE SURE THAT NO UNAUTHORIZED PERSON IS WITHIN THE WORKING AREA OF THE MACHINE, WHERE THERE IS A DANGER OF BEING STRUCK BY AN OBJECT THROWN OUT OF THE MACHINE
- ENSURE THAT ALL GUARDS ARE FITTED CORRECTLY AND ARE IN GOOD CONDITION, KEEP HANDS, FEET AND CLOTHING ETC WELL AWAY FROM ALL MOVING PARTS
- ALWAYS DISENGAGE THE PTO BEFORE DISMOUNTING FROM THE TRACTOR
- DO NOT ALLOW AN UNQUALIFIED OR INEXPERIENCED PERSON OR A CHILD TO GO NEAR THE MACHINE
- DO NOT LUBRICATE, CLEAN OR ADJUST THE MACHINE WITHOUT FIRST DISENGAGING THE PTO AND STOPPING THE TRACTOR ENGINE
- ENSURE THAT THE ROTOR OF THE MACHINE HAS COME TO A COMPLETE STOP
- CHECK THAT ALL NUTS AND BOLTS ARE TIGHT ESPECIALLY THOSE CONNECTING THE HAMMERS TO THE ROTOR
- FREQUENTLY INSPECT THE MACHINE FOR LOOSE PARTS, PARTICULARLY BEFORE STARTING WORK
- BEFORE STARTING WORK INSPECT THE WORK AREA FOR OBSTRUCTIONS AND WIRE
- WHEN OPERATING ON STEEP GROUND MAKE SURE THAT OPERATIONS ARE CARRIED OUT IN THE SAFEST POSSIBLE MANNER AVOIDING DITCHES OR OTHER OBSTACLES WHICH MAY CAUSE THE TRACTOR TO OVERTURN

F

- ASSUREZ-VOUS QU'AUUNE PERSONNE NON-AUTORISÉE RESTE À PROXIMITÉ DU BROUEUR
- VÉRIFIEZ QUE TOUS LES ÉLÉMENTS DE PROTECTION SOIENT EN PLACE, NE METTEZ PAS LES MAINS, PIEDS ET VÊTEMENTS PROCHE DES PIÈCES ROTATIVES
- DÉBRAYEZ TOUJOURS LA PRISE DE FORCE AVANT DE QUITTER VOTRE TRACTEUR
- N'AUTORISEZ AUCUNE PRÉSENCE D'UNE PERSONNE INEXPÉRIMENTÉE OU D'ENFANTS À S'APPROCHER DE LA MACHINE
- N'ENTREPRENEZ PAS DES TRAVAUX DE RÉPARATION SANS AVOIR DÉBRAYÉ LA PRISE DE FORCE, ATTENDEZ L'ARRÊTE TOTAL DE L'APPAREIL AVANT DE PROCÉDER AU GRAISSAGE, AU NETTOYAGE OU À UNE RÉPARATION
- VÉRIFIEZ RÉGULIÈREMENT LE BON SERRAGE DES BOULONS ET ÉCROUS QUI TIENNENT LES PIÈCES ROTATIVES DU ROTOR
- CONTRÔLEZ L'APPAREIL AVANT CHAQUE MISE EN SERVICE POUR DÉTECTER ET ÉLIMINER DES PIÈCES MAL FIXÉES
- INSPECTEZ LE TERRAIN AVANT DE COMMENCER VOTRE TRAVAIL QUANT À LA PRÉSENCE DE CORPS ÉTRANGERS TELS QUE FILS DE FER, ETC.
- PRUDENCE, SI VOUS TRAVAILLEZ EN TERRAIN ACCIDENTÉ, ÉVITEZ DE FAIRE PATINER LE ROUES OU DE LES BLOQUER CONTRE UN OBSTACLE, CELA PEUT ENTRAÎNER LE RENVERSEMENT DU TRACTEUR. VEUILLEZ ÉGALEMENT AU BON CHOIX DE PNEUS EN CORRESPONDANCE AVEC LE POIDS TOTAL DE L'ENSEMBLE.

Label 2 3

50 m

**DISTANZA DI SICUREZZA
SAFETY DISTANCE
DISTANCES DE SECURITE
SICHERHEITSABSTAND**

I **ATTENZIONE!** PER COMPIERE LA REVERSIBILITÀ DI TAGLIO ATTENDERE CHE IL ROTORE SIA COMPLETAMENTE FERMO.

F **ATTENTION!** INVERTIR LE SENS DE ROTATION SEULEMENT QUAND LE ROTOR EST ARRÊTÉ.

GB **WARNING!** SWITCH ROTOR TO OFF POSITION BEFORE INVERTING ROTATION.

D **VORSICHT!** DREHRICHTUNG UMKEHREN NUR BEIM AUSGESCHALTETEN ROTOR.

Label 4-6

Identification of the machine

You will find on frame of each machine: the EC mark and a plate reporting the information about the constructor, the model and the serial number, the year of construction, the weight.

ASSEMBLY

Tractor requirements

Before preparing the tractor for the machine make sure that specifications of the tractor meet the requirements listed below.

- A. 6 spline P.T.O. of 1-3/8" dia.
- B. A P.T.O. output of 540 rev/min.
- C. A top link is available.
- D. As a guide for suitable tractor size the ballasted weight of tractor should exceed 2750 kg (6050 lbs)
- E. Adequate ballast should be added to the rear wheel opposite to the arms and front of the tractor to ensure stability. The amount will vary depending on type of tractor used and prevailing conditions.

MACHINE PREPARATION

The machine will normally be delivered with the arms fully assembled to the mainframe, but with the mower head detached.

. When lifting machine in anything other than this conditions extreme care should be exercised as the center of gravity may change. Only personnel experienced in lift and hoist operation should attempt it. Note the Lifting Point and transport straps / retaining chain differ between the

- A. Position the machine on a flat hard surface.
- B. If not already fitted, lift the machine and fit the parking stands which will be found stored under the mainframe.

FITTING MACHINE TO TRACTOR

To fit the machine to the tractor follow the instructions carefully.

The machine is supported on the three-point linkage of the tractor, together with a rigid frame between the mainframe and top link attachment of the tractor

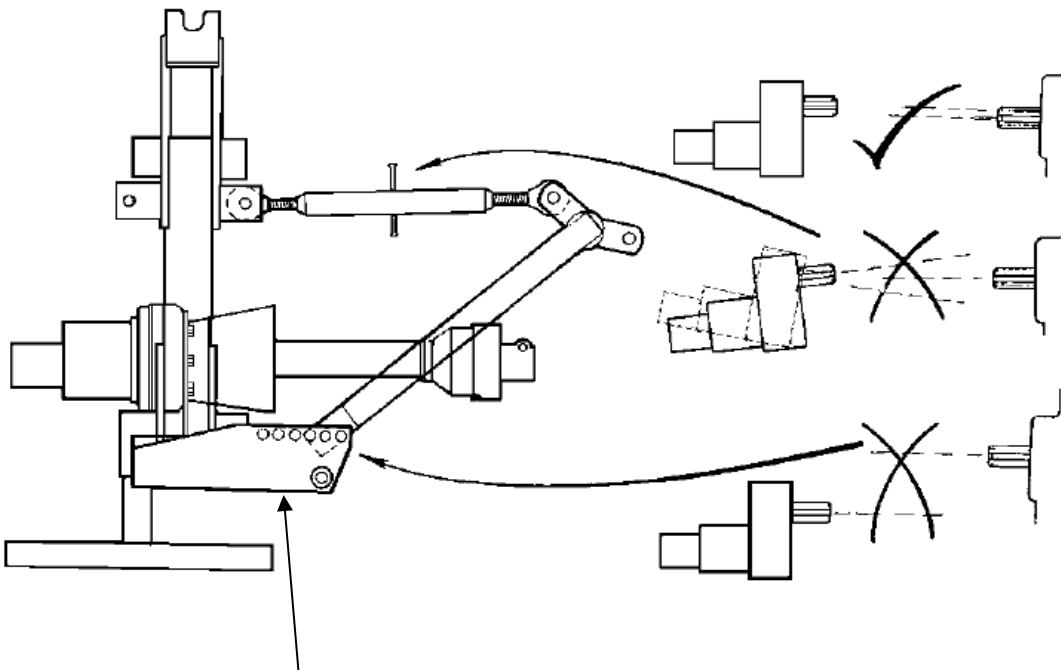
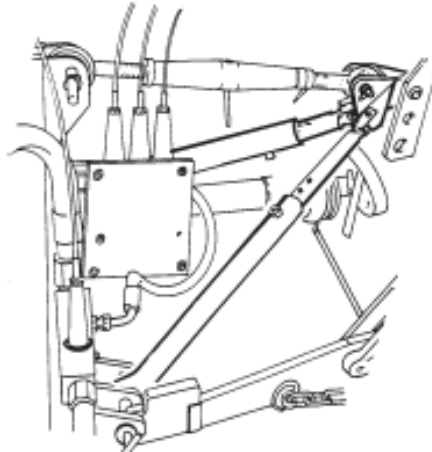

If it is required to mount the machine on a different tractor, it will be necessary to assembly a new plate for the lateral arms

Fitting controls

The position of the lever unit inside the tractor cab depends largely upon the route of the cables between unit and control valve.

The control valve is mounted on the front face of the oil tank.

The cable normally can be routed through the rear cab window and should be as free of bends as possible. **DO NOT PINCH CABLE IN CLOSED WINDOW.**

NOTE: Avoid sharp bends. The rotor control cable must not have a bend of less than 150mm (6 in) radius.

If the tractor cab has special apertures for cables the lever unit should be through them before they are attached to the tractor cab.

Follow instructions below for fitting lever unit.

A. Pass lever unit and cable through suitable aperture in rear of tractor cab.

NOTE: It is essential not to drill mounting holes through any structural member of the safety cab.

B. Mount the unit securely on to the mounting bracket with bolts provided.

C. Finally, check levers for smooth operation in both directions. If any stiffness is felt or if levers do not return to center, check cable route for sharp bends.

Hydraulic systems

It is not necessary to connect to the tractor hydraulics. The second pump, mounted on the PTO - driven gearbox, provides the hydraulic supply to the control valve for operation of the rams. A diverter valve in the main rotor drive circuit, operated by remote cable control, allows the rotor unit to be stopped while the PTO drive is in operation.

FILL TANK WITH OIL

NOTE: Before filling tank with oil connect the Drive Hose together, using one of the adaptors from the motor fitted to the cowl.

The correct procedure for filling the oil tank is as follows:

A. Remove breather cap and strainer assembly and place at side of tank.

B. Check unions on suction hose from tank to pumps for tightness and freedom from kinks and restrictions

C. Fill tank with 20 liters of oil.

D. Replace breather cap and strainer assembly.

E. Avoid contamination at all time, particularly when the breather cap and strainer assembly are removed.

Hose layout

It is important that hoses are fitted correctly. To ensure that there are no kinks, sharp bends and that the hoses do not chafe against sharp edges, the following layout should be used as a guide.

Twists

Hoses should never be twisted or kinked. On most hoses there is a line which runs the full length of the hose acting as a useful guide (see **FIGURE 3-8**). If there is no guideline running along the hose follow the fitting instructions below

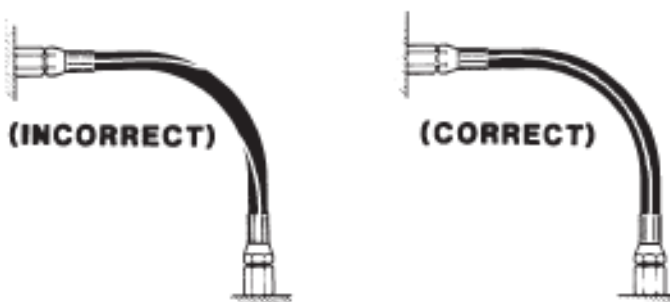
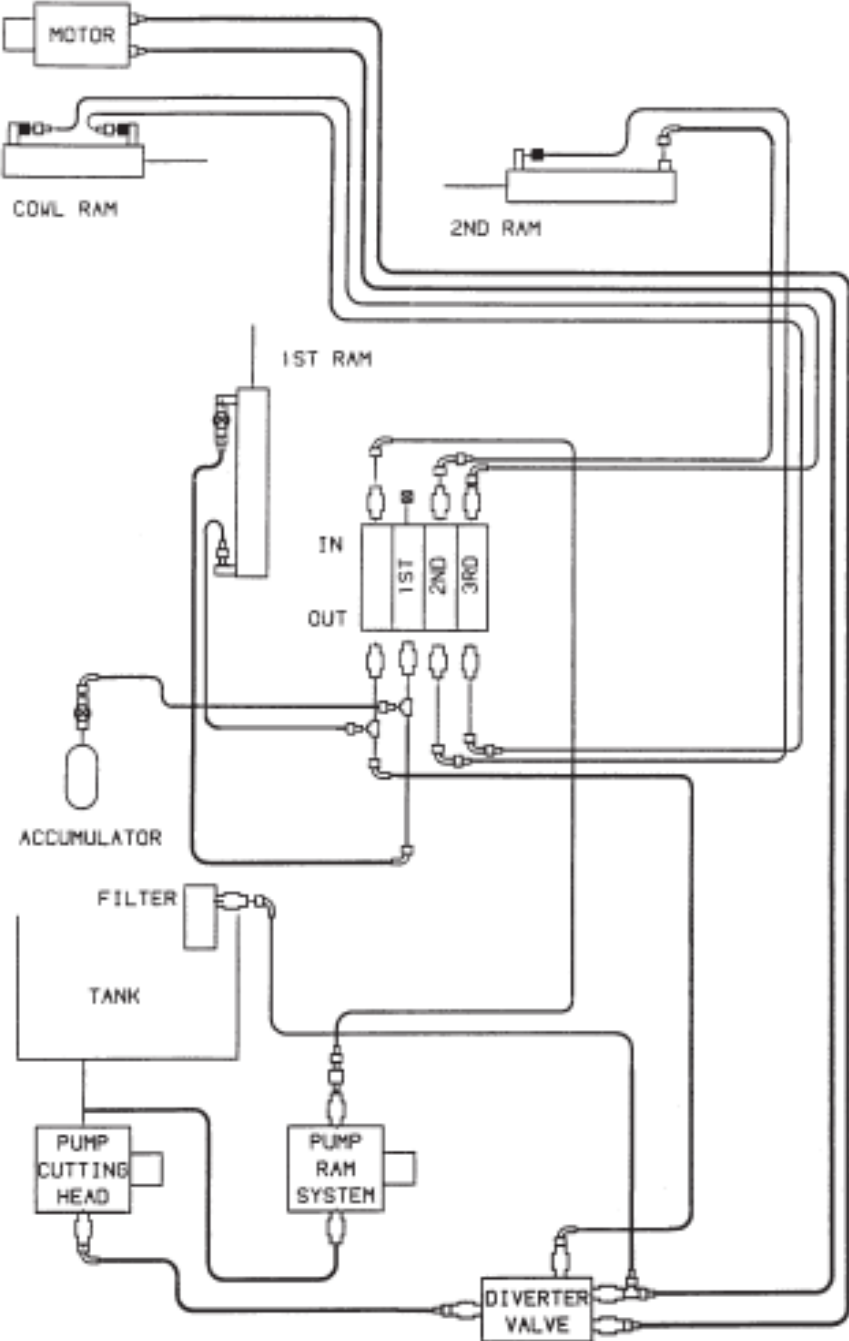

FIGURE 3-8



FIGURE 3-6



OPERATOR REQUIREMENTS

Safe operation of the unit is the responsibility of a qualified operator. A qualified operator has read and understands the implement and tractor Operator's Manuals and is experienced in implement and tractor operation and all associated safety practices. In addition to the safety messages contained in this manual, safety signs are affixed to the implement and tractor. If any part of the operation and safe use of this equipment is not completely understood, consult an authorized dealer for a complete explanation.

If the operator cannot read the manuals for themselves or does not completely understand the operation of the equipment, it is not the responsibility of we to read and explain the manuals, safety practices, and operating instructions to the operator, but operator itself.

Safe operation of equipment requires that the operator wear approved Personal Protective Equipment (PPE) for the job conditions when attaching, operating, servicing, and repairing the equipment. PPE is designed to provide operator protection and includes the following safety wear:

PERSONAL PROTECTIVE EQUIPMENT (PPE)

- Protective Eye Glasses, Goggles, or Face Shield
- Hard Hat
- Steel Toe Safety Footwear
- Gloves
- Hearing Protection
- Close Fitting Clothing
- Respirator or Filter Mask (depends on operating conditions)

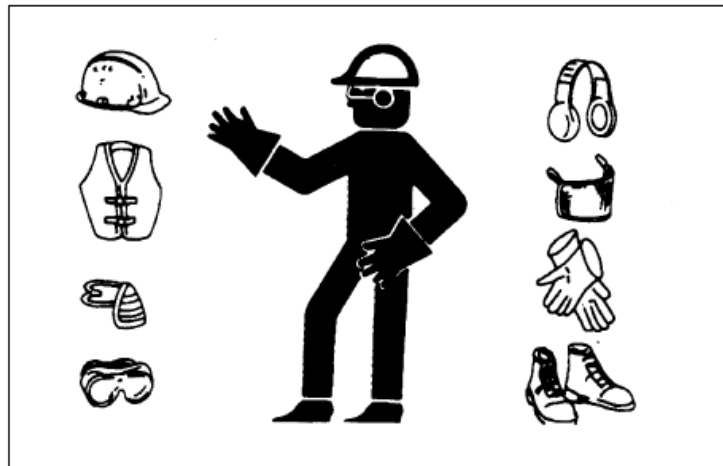

MAINTENANCE

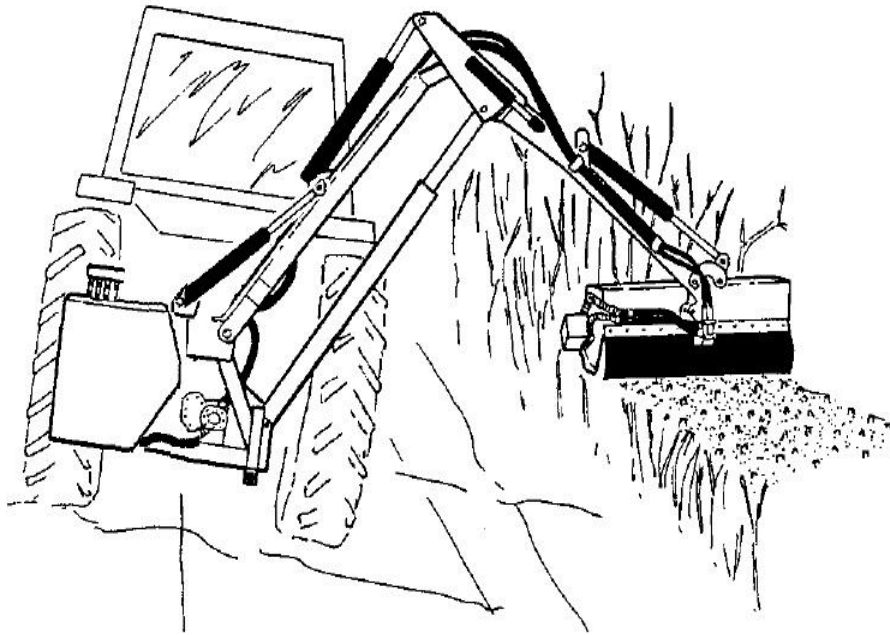

LUBRICATION

Gearbox

it is recommended that the oil level is checked before the machine is used. Change the oil after the first 200 hours of operation and thereafter every 1600 hours of operation.

Grease Points

All grease points shown in **FIGURE 5-1** below should be greased before operating the machine. To make greasing easier by relieving the weight from the pivot pins, rest the rotor unit on the ground, stop tractor engine and operate control levers in both directions. Grease daily or every 8 hours of operation. Use a high quality lithium base #2 grease.

n

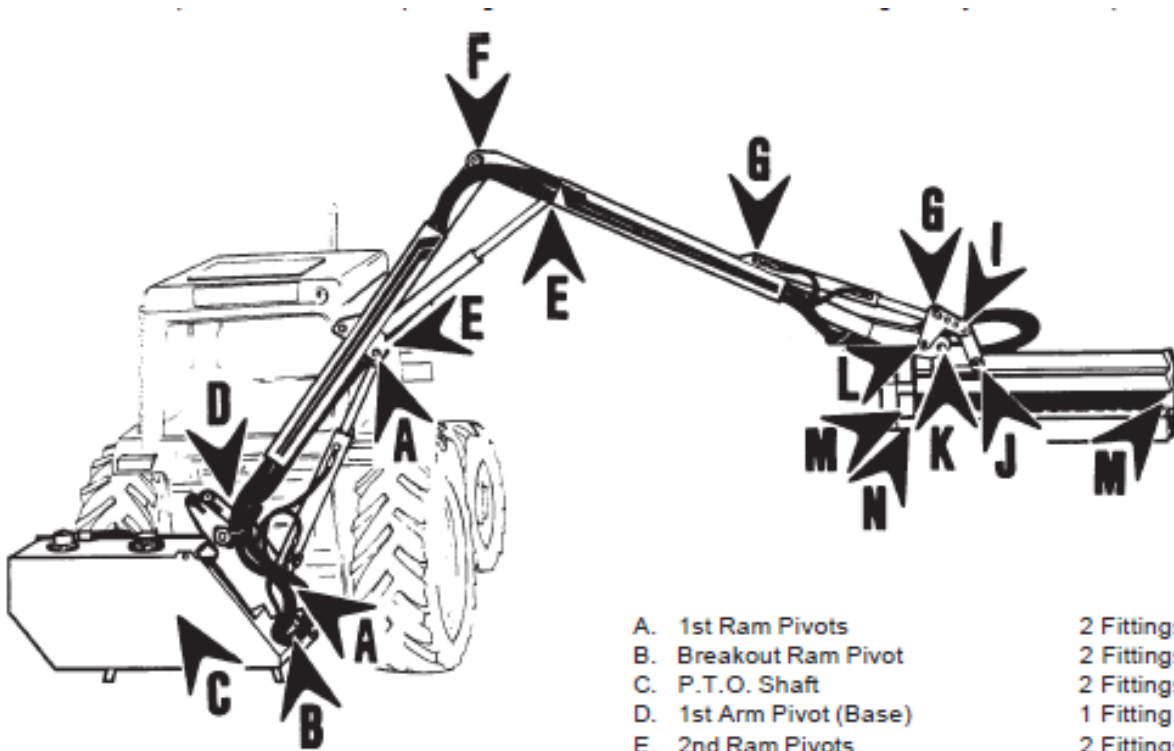

FIGURE 5-1

A.	1st Ram Pivots	2 Fittings
B.	Breakout Ram Pivot	2 Fittings
C.	P.T.O. Shaft	2 Fittings
D.	1st Arm Pivot (Base)	1 Fitting
E.	2nd Ram Pivots	2 Fittings
F.	1st and 2nd Arm Pivot	2 Fittings
G.	3rd Ram Pivots	2 Fittings
H.	Rotor Link / Ram Pivot	2 Fittings
I.	Rotor Link Pivot	1 Fitting
L.	Rotor Unit Pivot	1 Fitting
M.	Rotor Shaft Bearing	1 Fittings

Total 20 Fittings

***NOTE:**

Lubricate flail roller bearing until lubricant can be seen coming out between roller and bearing housing.

Filter replacement

The Filter Element, Situated in the filter unit in the top of the tank, must be replaced initially after 50 Hours work, and thereafter every 500 hours of work, or after two season's work, which ever is sooner.

Hoses and rotor drive circuit

It is false economy to try and make a damage hose last a bit longer, because a failure can spill several gallons of oil on the road endangering traffic and costing money. To reduce the risk of this happening and ensure a long life from the hoses follow instructions given below:

- A. Check weekly that all hoses and their connections (with particular attention to the rotor drive circuit) are in good condition and that there are no leaks or damage.
- B. Replace any hose that is leaking or damaged.
- C. Ensure that hoses have not chafed against sharp edges. If they have, inspect damage and replace if necessary.
- D. Re-route any hose that has been chafing.
- E. Ensure that when fitting hoses that they are fitted without kinks or sharp bends.
- F. Pay particular attention to the suction hose from tank to pump.
- G. If in doubt about the condition of a hose REPLACE IT.

HYDRAULIC OILS

Only use Universal Hydraulic Oil part number

PUMP

A 'noisy' pump (whistling or screaming) means that there is air in the rotor drive circuit.

- A. STOP THE MACHINE AT ONCE.
- B. Locate air entry.
- C. Fix and test carefully.

Maintenance Section 5-4

Rotor unit

Vibration of the rotor shaft can cause premature failure of the rotor shaft bearing, as well as hydraulic and structural failures. It is important not to operate the machine with the head vibrating. As soon as any vibration is felt stop operating the machine and make the checks listed below:

- A. Stop the tractor and disengage the PTO drive.
- B. Check for missing flails and always replace missing flails in pairs, on opposite sides of the rotor in order to maintain the balance of the rotor shaft.. Replace one flail, hanger, bolts and other fittings - rotate shaft 180° and replace the same for each flail.

NOTE: The flails and the rotor shaft are dynamically balanced, the flails must be replaced in pairs. If this is not done the rotor shaft may become out of balance and cause excessive vibration.

- C. Check that flail attachments are tight.

If any flails were missing or loose and have been replaced or tightened and the vibration continues check the following.

- D. Stop tractor engine and disengage PTO drive.
- E. Check the Rotor Shaft bearings to see if they are damaged or loose.
- F. Replace bearings if necessary.

If vibration persists, it is an indication that the rotor shaft is probably bent and must be replaced.

Hydraulic Cylinders

It is advisable to check all cylinder caps for tightness occasionally and if found to be loose, tighten them immediately.

Storage

Before removing the machine from the tractor, a thorough check of the machine should be made as follows:

- A. Thoroughly clean all moving parts, particularly the rotor unit.
- B. Check that all flails are in place, and that they are in good condition.
- C. Check all hoses for damage, such as cracks, evidence of chafing and leaks.
- D. Smear all unpainted metal parts with grease and lubricate all grease fittings.
- E. Make a note of item that needs replacing so that parts can be ordered.

Parking and removal

In the parked position the machine is supported by four stands on the mainframe and also the rotor unit. To put the machine into this position the following procedure is necessary:

- A. Place the rotor unit on the ground about 1 meter (3ft 3in) from the tractor rear wheel.
- B. Remove stands from underneath the tank and fit to the mainframe.
- C. Lengthen to link so that the weight of the machine is on the rear stand.
- D. Remove pin connecting the right frame to the tractor, and lower the three point linkage so that the weight of the machine is on the front stands.
- E. Stop Tractor engine.
- F. Open accumulator valve and operate control levers in both directions to release pressure.
- G. CLOSE ISOLATOR VALVES ON FIRST ARM AND ACCUMULATOR (IF FITTED).
- H. Remove control lever unit from inside tractor and feed through rear of cab without bending cable too tightly. Tie unit onto mainframe and protect from weather.
- I. Disconnect cable from control box to control valve and feed through rear of cab.
- J. Release tractor end of PTO shaft and pull back along splined (on some tractors it may not be possible to remove the PTO completely at this stage).
- K. Remove lower link pins.
- L. Start tractor engine and drive carefully forward, releasing machine and PTO shaft from tractor.
- M. Replace lower link pins and place cap over tractor PTO.
- N. Remove control box from cab and store in a clean dry place

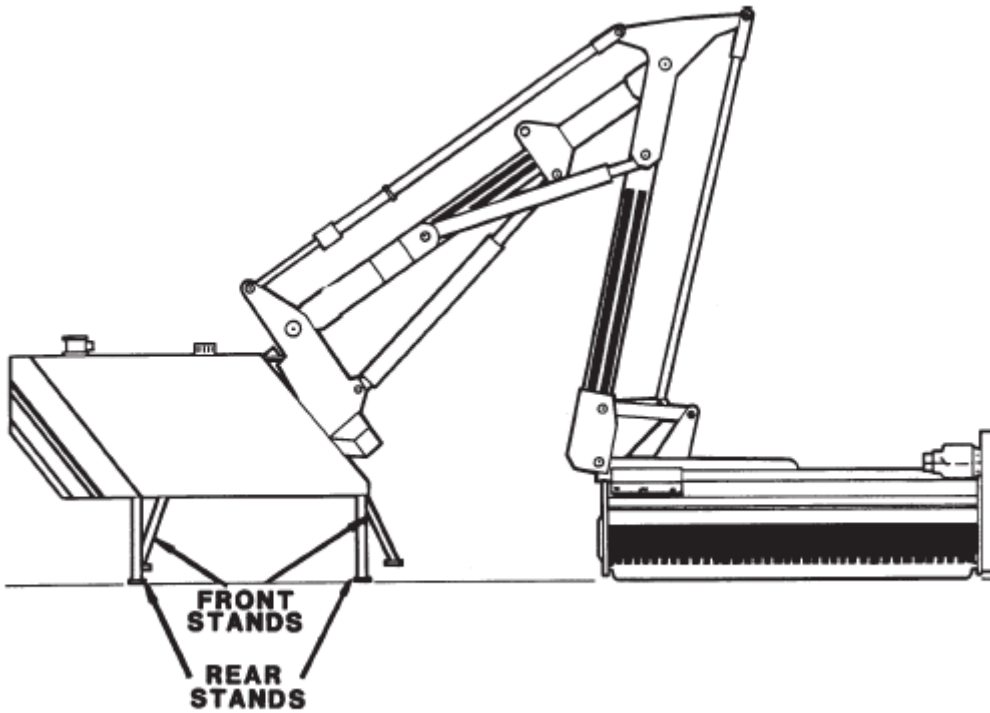

Proper torque for fasteners (figure 5-3)

The chart lists the correct tightening torque for fasteners. When bolts are to be tightened or replaced, refer to this chart to determine the grade of bolts and the proper torque except when specific torque values are assigned in manual text.

Proper Torque values for bolts that are measured in Inches

Proper Torque values for Metric bolts

Bolt Diameter			
	Head Marking No Marks Grade Two	Head Marking Three Lines Grade Five	Head Marking Six Lines Grade Eight
	Pound - Foot Value Dry	Pound - Foot Value Dry	Pound - Foot Value Dry
1/4"	5.5	9	12.5
5/16"	11	18	26
3/8"	20	33	46
7/16"	32	52	75
1/2"	50	80	115
9/16"	70	115	160
5/8"	100	160	225
3/4"	175	280	400
7/8"	175	450	650
1"	270	675	975
1-1/8"	375	850	1350
1-1/4"	530	1200	1950
1-3/8"	700	1650	2550
1-1/2"	930	2100	3350

Bolt Diameter				
	Head Marking 4.3	Head Marking 8.8 or 9.8	Head Marking 10.9	Head Marking 12.9
	Pound - Foot Value Dry	Pound - Foot Value Dry	Pound - Foot Value Dry	Pound - Foot Value Dry
6mm	4.5	8.5	12	14.5
8mm	11	20	30	35
10mm	21	40	60	70
12mm	37	70	105	120
14mm	60	110	165	190
16mm	92	175	255	300
18mm	125	250	350	410
20mm	180	350	500	580
22mm	250	475	675	800
24mm	310	600	850	1000
27mm	450	875	1250	1500
30mm	625	1200	1700	2000

FIGURE 5-3

*To get Newton-Meters multiply pound-foot of torque by 1.356

CHECK OF THE LIFTING CAPABILITY AND OF THE STABILITY OF THE TRACTOR

Verify the lifting capability and the stability of the tractor through the following formula and if necessary apply frontally the ballasts

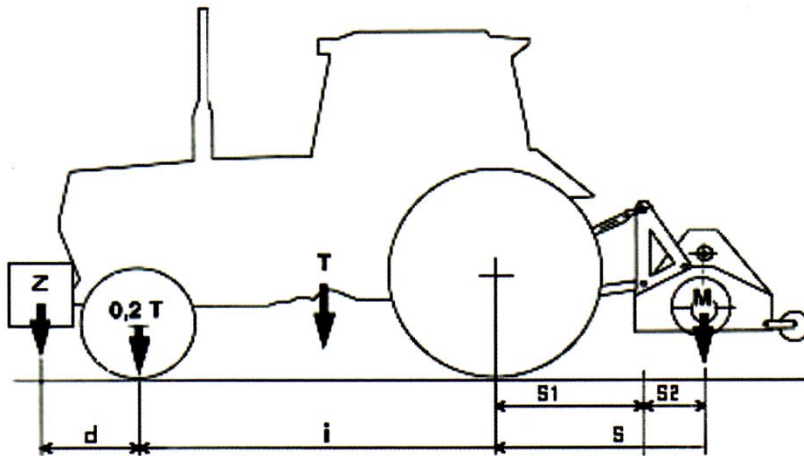

$$M \times s \leq 0,2 T \times i + Z (d + i)$$

$$M < 0,3 T$$

i	=	axle base wheels tractor
d	=	distance of the front axle from the ballasts
S	=	overhang of the rear axle of the operator machine S = S1 + S2
S1	=	distance of the tractor front axle to the end lifting arms
S2	=	distance of the shredder barycentre to the centre holes lifting pins
T	=	mass of the tractor + 75 kg (operator)
Z	=	Mass of the ballasts
M	=	mass of the whole loaded machine



DANGER!

It is obligatory to verify the lifting ability and the stability of the tractor to avoid its turnover and/or loss of adhesion of the steering wheels.

This manual cannot possibly cover all of the potentially hazardous situations you will encounter. By being familiar, though, with the safety rules, operating and maintenance instructions in this manual you can help prevent accidents. The objective of this manual is to help make you a better operator. Remember, **SAFETY IS YOU!**



Your safety and the safety of those around you depends on **YOU**. Common sense should play a large role in the operation of this machine.

