



Dirt Scoop Bucket

AGDBS4/AGDBS5/AGDBS6

OPERATION MANUAL



Ag Pro Australia Pty Ltd
3730 Harmony Way
Harcourt
Victoria 3453
1300 121 131
agpro@agproproducts.com.au

This manual is provided to assist you in getting the best results from your machine and ensure that you do so safely. If you have any queries about the use of the machine contact your dealer before use. Please keep this manual for future reference.

1.1 FUNDAMENTAL PRECAUTIONS

On delivery, your dealer gave you an explanation of the operation and maintenance of this Dirt Scoop Bucket. Please read and understand these operating instructions before operating the machine for the first time. It is essential that you observe all safety instructions.

Incorrect use or mishandling of the machine can endanger:

- Life and Limb of the operator, other persons or animals within the vicinity of the machine.
- The machine and other material assets of the owner or third persons.
- The performance of the machine.

Anyone who is involved in the commissioning, operation or maintenance of the Dirt Scoop Bucket must read and understand these instructions very carefully and observe them at all times.

NEVER DISTRACT ANYONE WHO IS USING A MACHINE.

1.2 AUTHORISED OPERATORS

Youths under the age of 16 must not operate this implement. The owner of the machine must provide the operator with the operating instructions and make sure they have read and understood them. Only then may the machine be put into operation.

The owner must ensure that only authorised persons operate/work on this machine. He is responsible for keeping any third persons or animals out of the working area of the machine.

A SAFE DISTANCE OF AT LEAST 5M MUST BE OBSERVED BY ANYONE WITHIN THE VICINITY OF THE DIRT SCOOP BUCKET.

1.3 GENERAL SAFETY AND ACCIDENT PREVENTION REGULATIONS

- Ensure the implement is correctly and securely attached to the operating vehicle 3-point linkage using the lift arm pins and locking lynch pins provided.
- **NEVER** attach to a tractor which would be rendered unstable when the implement is operated at its full capacity. Take note of the maximum load permissible on linkage arms. Info on the weight of the boxes is given in the table below.

Model	Tractor HP	Max Load Capacity
AGDBS4	16-40	300kg
AGDBS5	30-70	500kg
AGDBS6	40-90	700kg

•When detaching the implement from the tractor always ensure that that it is stable and is safely positioned on a level surface.

•**NEVER** attempt to move this implement manually.

•Take extra care when operating machinery on sloping ground. **NEVER** operate on ground where there is a risk of the tractor becoming unstable.

•**ALWAYS** ensure that the rope attaching the tripping mechanism to the tractor is detached and safely stored before detaching the implement from the tractor.

•**WARNING:** The attaching and detaching of the implement to a tractor must be carried out by only one operator. There should not be any other people in the vicinity of the implement or in the tractor.

•**ALWAYS** ensure that the trip mechanism is securely closed before attaching or detaching the implement from the tractor.

•Before operation make yourself familiar with all elements and controls of the machine as well as their functions.

•Before operation inspect the area around you. Keep children away. All visitors and unauthorised persons should be kept well away from work area.

•**UNDER NO CIRCUMSTANCES SHOULD ANYONE, AUTHORISED OR OTHERWISE ATTEMPT TO USE THE DIRT SCOOP BUCKET AS A MEANS OF PERSONAL TRANSPORT.** It is designed as a specialist purpose farm implement and is unsuitable for the safe transportation of passengers. **NEVER** allow anyone especially children to travel or play anywhere on or around the tractor and an implement.

•To avoid personal injury keep hands and limbs well away from the moving parts and from between the hitch and the main body.

4.4 GENERAL OPERATING INSTRUCTIONS

•This is a tractor mounted implement. Attempts should not be made to attach the implement to any other type of vehicle. If the Dirt scoop Bucket is to be transported on a trailer then it should be securely attached using suitable restraints.

•Never use incorrectly sized lift arm or top link pins when attaching the Dirt Scoop Bucket.

•Attach a suitable length of rope to the eye on the tipping mechanism so this mechanism can be operated safely from the cab. Ensure that the length of the rope used allows the free movement of the implement from the maximum to minimum heights and that there is no possibility of the slack rope becoming entangled and risking life or limb.

•Tip the box by releasing the tipping hitch.

•Once tipped, lower the box until the tipping hitch clips back into the normal operating position.

1.5 MAINTENANCE

- As a rule, disengage the driving system, apply the handbrake and stop the engine prior to carrying out maintenance, servicing, cleaning or repair work. **ALWAYS** remove the ignition key.
- Prop the machine with appropriate supports before carrying out any maintenance work.
- The manufacturer will not be responsible for any damages or injuries caused by unauthorised repair, alterations or mishandling of the product.
- Maintain product with care. Grease all hinges frequently and check periodically for damage that would affect the safe operation of the implement.
- ALWAYS** ensure all warning stickers are kept clean and in good condition.

Dirt Scoop Bucket Assembly

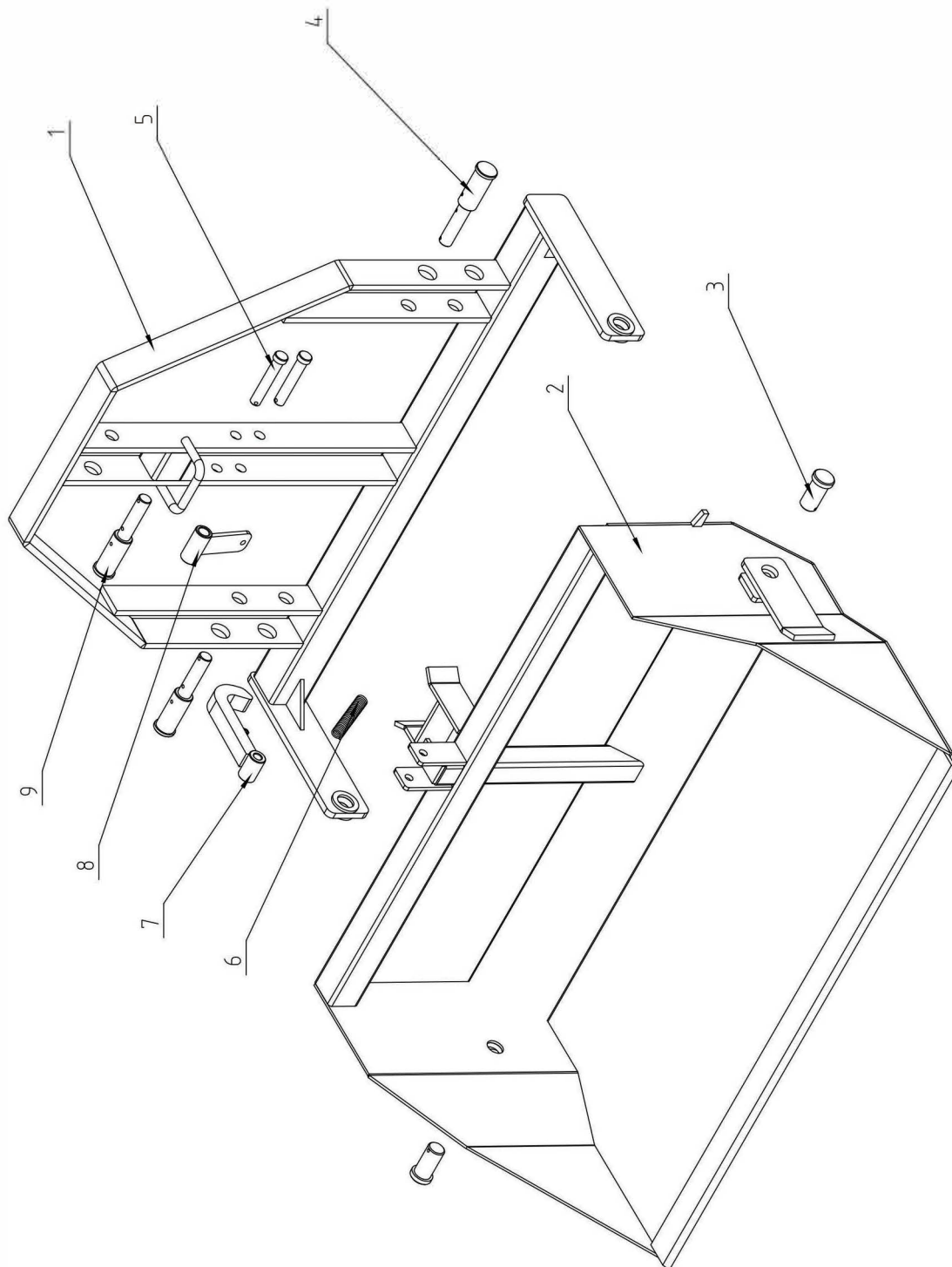

Dirt Scoop Bucket Parts List

No.	Quantity	Name&Specification
1	1	Main Frame
2	1	Bucket
3	2	Rotary Pin
4	2	Below Suspension Pin
5	2	Card Hook Pin
6	1	Spring
7	1	Hook
8	1	Extractor
9	1	Upper Suspension Pin